

# **Ethernet in Substation Automation Applications – Issues and Requirements**

Marzio P. Pozzuoli

RuggedCom Inc. – Industrial Strength Networks  
Concord, Ontario, Canada

## **Introduction**

Trends in electric utility automation, specifically substation automation, have converged upon a common communications architecture with the goal of having interoperability between a variety of Intelligent Electronic Devices (IEDs) found in the substation. This initiative was begun back in the late 1980s driven by the major North American utilities under the technical auspices of EPRI (Electric Power Research Institute). The resulting standard that emerged is known as the Utility Communications Architecture 2.0 (UCA2.0) and is now becoming an international standard as IEC 61850. This architecture, which is now being adopted worldwide by utilities and IED vendors alike, has as its underlying network technology - Ethernet.

This paper looks at the key issues and requirements for Ethernet in the substation environment and for substation automation applications requiring real-time performance. Specific topics addressed are: EMI phenomena and atmospheric conditions in substations which can affect network performance, new standards introduced by the IEC and IEEE that establish new EMI and environmental requirements specifically for communications networks (i.e. Ethernet) in substations, critical Layer-2 features of modern Ethernet switching hubs (i.e. switches) which enhance real-time deterministic performance as well as fault tolerant loop architectures and network redundancy.

## **EMI Immunity Requirements**

The proliferation of Ethernet capable IEDs used for substation automation has increased markedly in the past several years. There are currently nine vendors of protective relaying devices alone offering Ethernet communications with their IEDs. Vendors of meters, RTUs and PLCs used for substation automation, also mirror this trend. A key requirement of most substations IEDs such as protection relays is that they must operate properly (i.e. not ‘misoperate’) under the influence of a variety of EMI phenomena commonly found in the substation. Standards such as IEEE C37.90.x and IEC 60255 define a variety of type withstands tests designed to simulate EMI phenomena such as inductive load switching, lightning strikes, electrostatic discharges from human contact, radio frequency interference due to personnel using portable radio handsets, ground potential rise resulting from high current fault conditions within the substation and a variety of other EMI phenomena commonly encountered in the substation. This will also be true of the substation LAN equipment (i.e. the Ethernet switches). Often the Ethernet switches will be installed in the same compartment or even on the same rack as protective relaying IEDs. Therefore, it has become necessary that the Ethernet

equipment become “substation hardened”, from an EMI immunity perspective, to the same level as protective relaying IEDs.

### IEC 61850-3 Communications Networks and Systems in Substations

In recognition of the above requirements the IEC (International Electrotechnical Commission) issued a new standard in January 2002 entitled: *IEC 61850-3 Communications Networks and Systems in Substations – Part 3: General Requirements*. Section 5.7 of the standard outlines the EMI immunity requirements for communications equipment installed in substations. In general, it sets a higher standard than the immunity requirements for equipment in industrial environments stating that: *“The general immunity requirements for the industrial environment are considered not sufficient for substations. Therefore, dedicated requirements are defined in IEC 61000-6-5...”* [1]

*The IEC 61000-6-5: “Generic Standards – Immunity for power station and substation environments”* outlines the EMI immunity requirements. The details of these requirements and type test procedures are given in the parts of the IEC 61000-4-x series. Figure 1 shows the relationship between IEC 61850-3, IEC

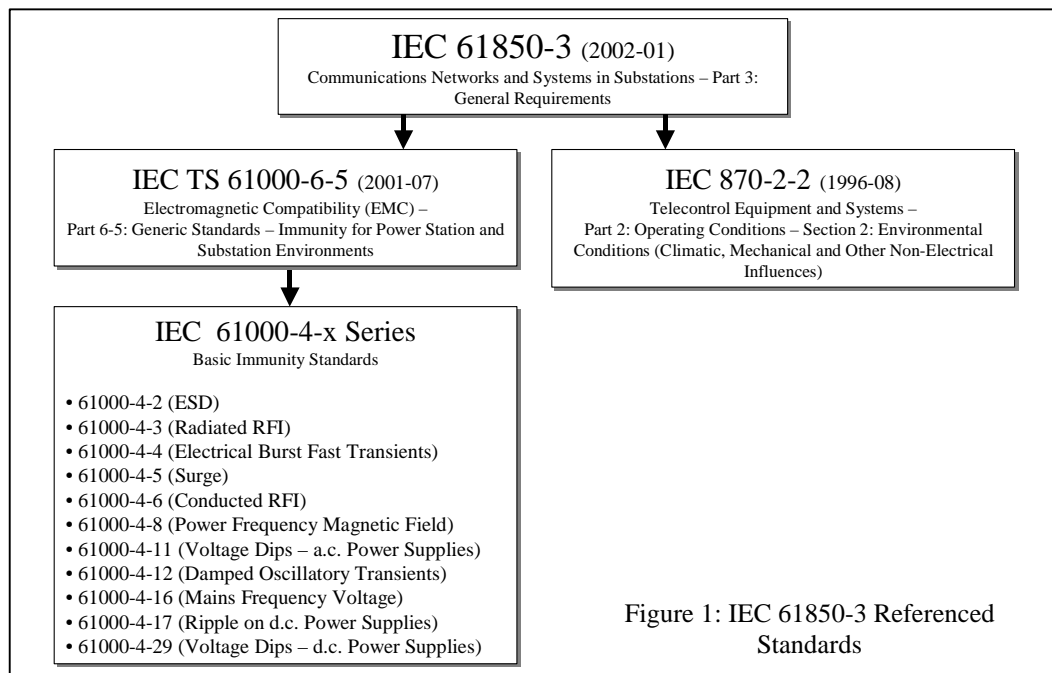

61000-6-5, the IEC 61000-4-x series and other referenced standards.

IEC 61000-6-5 defines port categories. A ‘port’ is defined as a “*particular interface of the specified equipment with the external electromagnetic environment*”[2]. There are five port categories defined:

1. Enclosure Port (typically the device enclosure)
2. Signal Port (a connection to local, field, high voltage, or telecom equipment)
3. Low Voltage a.c. Input Power and Output Power Ports

4. Low Voltage d.c. Input Power and Output Power Ports
5. Functional Earth Port

In addition to ‘port’ definitions IEC 61000-6-5 also defines categories of locations:

- G** = power stations and MV substations
- H** = HV substations
- P** = “protected” areas if any

Also defined are *Signal Port* connections:

- L** = local connections
- f** = field connections
- h** = connections to HV equipment
- t** = telecom
- p** = connections within a protected area if any

Figure 2 shows a typical substation defined in terms of Locations and Signal Port

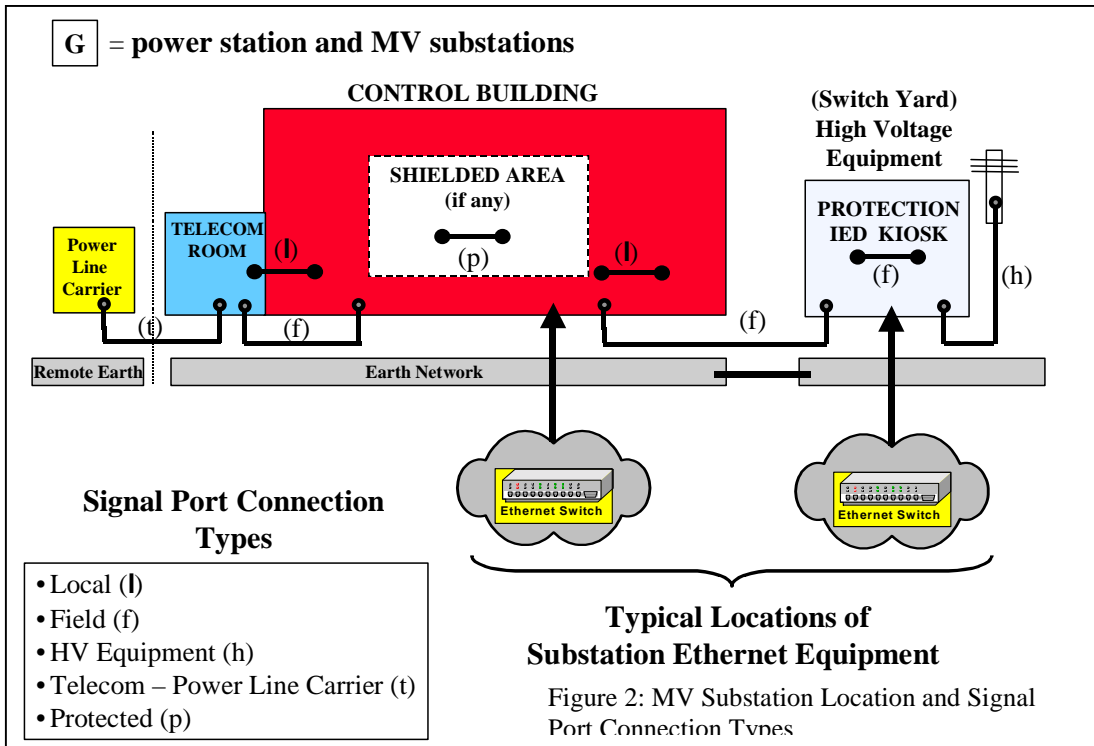

connections. Specific IEC 61000-4-x Tests and corresponding test levels are assigned to each port type (e.g. enclosure, power, signal) based on device location (e.g. H = HV Substations, G = Power Stations or MV substations) and *signal* port connection types (e.g. local, field, HV, telecom, protection) in the case of *signal* port types. Table 1 lists the resultant type test profile and corresponding test levels for network equipment located in the Protection Kiosk in MV substation shown in Figure 2.

UTILITY IEC 61850-3 (61000-6-5) Communications Networks and Systems In Substations (Jan 2002)				
TEST	Description	Test Levels		Severity Levels
IEC 61000-4-2	ESD	Enclosure Contact	+/- 6kV	3
		Enclosure Air	+/- 8kV	3
IEC 61000-4-3	Radiated RFI	Enclosure ports	10 V/m	3
		Signal ports	+/- 4kV @ 2.5kHz	x
IEC 61000-4-4	Burst (Fast Transient)	D.C. Power ports	+/- 4kV	4
		A.C. Power ports	+/- 4kV	4
		Earth ground ports <sup>3</sup>	+/- 4kV	4
		Signal ports	+/- 4kV line-to-earth, +/- 2kV line-to-line	4
IEC 61000-4-5	Surge	D.C. Power ports	+/- 2kV line-to-earth, +/- 1kV line-to-line	3
		A.C. Power ports	+/- 4kV line-to-earth, +/- 2kV line-to-line	4
		Signal ports	10V	3
IEC 61000-4-6	Induced (Conducted) RFI	D.C Power ports	10V	3
		A.C. Power ports	10V	3
		Earth ground ports <sup>3</sup>	10V	3
		Enclosure ports	40 A/m continuous, 1000 A/m for 1 s	N/A
IEC 61000-4-8	Magnetic Field	D.C. Power ports	30% for 0.1s, 60% for 0.1s, 100% for 0.05s	N/A
IEC 61000-4-29	Voltage Dips & Interrupts	A.C. Power ports	30% for 1 period, 60% for 50 periods	N/A
IEC 61000-4-11		100% for 5 periods, 100% for 50 periods <sup>2</sup>	N/A	
IEC 61000-4-12	Damped Oscillatory	Signal ports	2.5kV common, 1kV differential mode @ 1MHz	3
		D.C. Power ports	2.5kV common, 1kV differential mode @ 1MHz	3
		A.C. Power ports	2.5kV common, 1kV differential mode @ 1MHz	3
IEC 61000-4-16	Mains Frequency Voltage	Signal ports	30V Continuous, 300V for 1s	4
		D.C. Power ports	30V Continuous, 300V for 1s	4
IEC 61000-4-17	Ripple on D.C. Power Supply	D.C. Power ports	10%	3

Table 1: Typical EMI Immunity Type Test Profile for Network Equipment Located in the Protection IED Kiosk of Figure 2

### IEEE P1613 - Draft Standard Environmental and Testing Requirements for Communications Networking Devices in Electric Power Substations

Expected to be released later this year (2003) is the IEEE P1613 standard for networking devices in substations. P1613 specifically adopts and adapts the EMI immunity type tests applied to protective relaying IEDs as defined by the familiar IEEE C37.90.x standards. Table 2 below summarizes the tests and test levels required in accordance with IEEE P1613.

IEEE P1613 – Draft Standard Environmental Requirements for Communications Devices Installed in Electric Power Substations				
TEST	Description	Test Levels		Severity Levels
IEEE C37.90.3	ESD	Enclosure Contact	+/- 8kV	N/A
		Enclosure Air	+/- 15kV	N/A
IEEE C37.90.2	Radiated RFI	Enclosure ports	35 V/m	N/A
IEEE C37.90.1	Fast Transient	Signal ports	+/- 4kV @ 2.5kHz	N/A
		D.C. Power ports	+/- 4kV	N/A
		A.C. Power ports	+/- 4kV	N/A
		Earth ground ports <sup>3</sup>	+/- 4kV	N/A
IEEE C37.90.1	Oscillatory	Signal ports	2.5kV common mode @ 1MHz	N/A
		D.C. Power ports	2.5kV common & differential mode @ 1MHz	N/A
		A.C. Power ports	2.5kV common & differential mode @ 1MHz	N/A
IEEE C37.90	Dielectric Strength	Signal ports	2kVac	N/A
		D.C. Power ports	2kVac	N/A
		A.C. Power ports	2kVac	N/A

Table 2: P1613 EMI Immunity Requirements based on IEEE C37.90.x Type Tests

P1613 also defines two different classes of communications devices: **Class 1** devices must withstand the type tests defined in Table 2 without sustaining damage or resetting but may incur communications errors during the applications of the type tests, **Class 2** devices however must meet the same requirements as Class 1 devices with the exception that no communications errors, delays or

interruptions occur during the application of the type tests defined in Table 2. **Class 2** network equipment is intended to provide the same level of performance as protective relaying devices during periods of high EMI stress as would be occur during a power system fault.

### **Environmental Requirements**

Both the IEC 61850-3 standard and the IEEE P1613 standard define atmospheric environmental requirements for network communications devices such as Ethernet switches in substations.

### **IEC 61850-3 Environmental Requirements**

IEC 61850-3 refers to IEC 870-2-2 “*Telecontrol equipment and systems – Part 2: Operating conditions – Section 2: Environmental conditions (climatic, mechanical and other non-electrical influences)*”. IEC 870-2-2 addresses the atmospheric environment which defines four classes of locations:

1. Class A: air-conditioned locations (indoor)
2. Class B: heated and/or cooled enclosed conditions
3. Class C: sheltered locations
4. Class D: outdoor locations

The majority of IEDs in substations will be in “Class C” locations. Class C locations are further sub-divided into four classes: C1, C2, C3 and Cx. Operating temperature ranges for each of the classes are as follows:

1. Class C1: -5 to 45°C
2. Class C2: -25 to 55°C
3. Class C3: -40 to 70°C
4. Class Cx: Special

For IEDs in substations classes C2, C3 or Cx (-40 to 85°C) will be required.

### **IEEE P1613 Environmental Requirements**

IEEE P1613 defines four temperature ranges: [3]

- a) -40 °C to +70 °C.
- b) -30 °C to +65 °C.
- c) -20 °C to +55 °C (the default range if no other range is specified).
- d) Range defined by the manufacturer

Furthermore clause 4 of the standard requires that not fans be used for cooling in the communications networking equipment.

### **Real-time Control Requirements**

Modern managed Ethernet switches offer advanced Layer 2 and Layer 3 features that are critical for real-time control and substation automation. These include: [4]

- ❑ **IEEE 802.3x Full-Duplex** operation on all ports ensures that no collisions occur and thereby makes Ethernet much more deterministic. There are absolutely zero collisions in connections that both support IEEE 802.3x Full-Duplex operation. This eliminates one of the biggest “bugaboos” about Ethernet and deterministic operation.
- ❑ **IEEE 802.1p Priority Queuing** which allows frames to be tagged with different priority levels in order to ensure that real-time critical traffic always makes it through the network even during high periods of congestion.
- ❑ **IEEE 802.1Q VLAN** which allows for the segregation and grouping of IED’s into virtual LAN’s in order to isolate real-time IED’s from data collection or less critical IED’s.
- ❑ **IEEE 802.1w Rapid Spanning Tree Protocol** which allows for the creation of fault tolerant ring network architectures that will reconfigure in milliseconds as opposed to tens of seconds as was the case for the original Spanning Tree Protocol 802.1D.
- ❑ **IGMP Snooping / Multicast Filtering** that allows for multicast data frames, such as GOOSE frames, to be filtered and assigned only to those IED’s which request to listen to them.

It is important to note that the above features are based on standards thereby ensuring interoperability amongst different vendors.

### **Network Architecture Requirements**

There are three basic network architectures (i.e. Cascading, Ring, and Star) that are commonly implemented with Ethernet Switches in substations with numerous variations and hybrids of the three. Each of the three basic architectures offers various performance vs. cost tradeoffs.

## Cascading (or Bus) Architecture

A typical cascading architecture is illustrated in Figure 3. Each switch is connected to

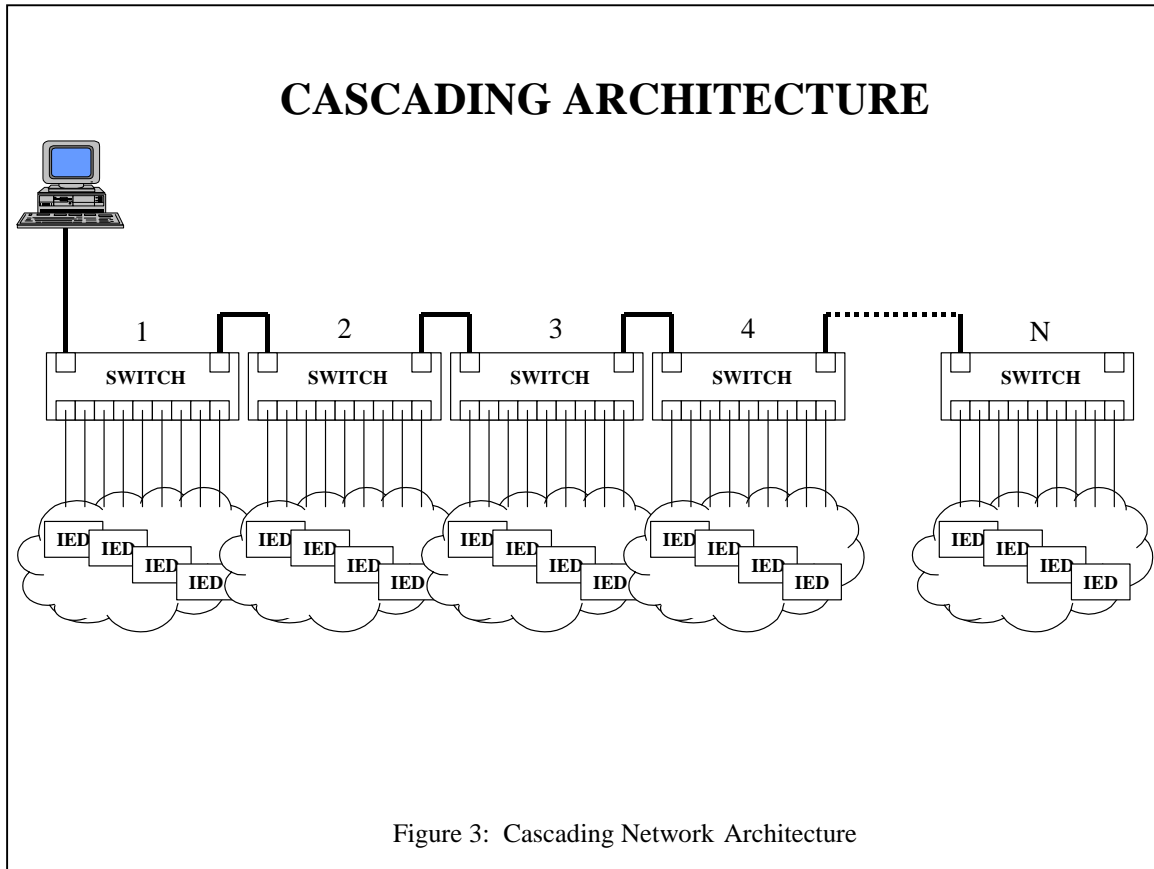

Figure 3: Cascading Network Architecture

the previous switch or next switch in the cascade via one of its ports. These ports are sometimes referred to as *uplink* ports and are often operating at a higher speed than the ports connected to the IED's. The maximum number of switches,  $N$ , which can be cascaded depends on the worst case delay (latency) which can be tolerated by the system. For example, consider the case where an IED connected to *Switch 1* sends a frame to an IED on *Switch 4*. The frame must endure the retransmission delays of Switch 1, Switch 2, and Switch 3 of the cascade or three 'hops'. Furthermore it will also be delayed by the internal processing time of each switch; a parameter commonly specified as the Switch Latency. Let's workout this example for a 64 Byte message frame assuming the following:

- ❑ Message Frame size = 64 Bytes
- ❑ Speed of Uplink ports (i.e. the ports forming the cascade) = 100Mbps
- ❑ Internal Switch Latency = 5us (typical for 100Mbps ports)

Therefore:

- ❑ The frame transmission time =  $64 \text{ Bytes} * 8\text{Bits/Byte} * 1/100\text{Mbps} = 5.12 \text{ us}$ .
- ❑ The total delay from *Switch 1* to *Switch 4* = (Frame Transmission Time + Internal Switch Latency) \* (# of 'Hops') =  $(5.12\text{us} + 5\text{us}) * 3 = 30.36\text{us}$
- ❑ The total delay from *Switch 1* to *Switch N* =  $(5.12\text{us} + 5\text{us}) * N = N*10.12\text{us}$

Advantages:

- ❑ Cost effective - allows for shorter wiring runs vs. bringing all connections to a central point.

Disadvantages:

- ❑ No Redundancy – if one of the cascade connections is lost every IED downstream of that connection is also lost.
- ❑ Latency – worst case delays across the cascading backbone have to be considered if the application is very time sensitive

## Ring Architecture

A typical ring architecture is shown in Figure 4. It is very similar to the Cascading

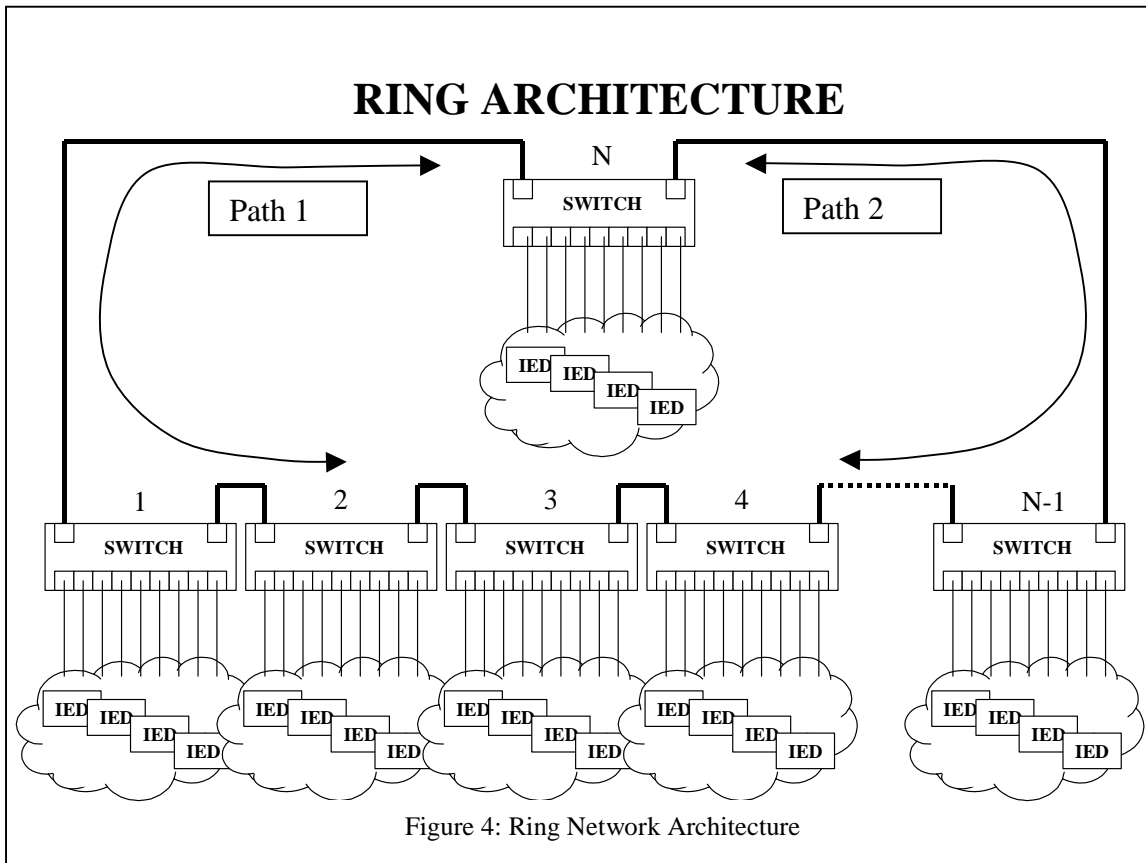

architecture except that the loop is closed from *Switch N* back to *Switch 1*. This provides some level of redundancy if any of the ring connections should fail. Normally, Ethernet Switches don't like "loops" since messages would circulate indefinitely in a loop and eventually eat up all of the available bandwidth. However, 'managed' switches (i.e. those with a management processor inside) take into consideration the potential for loops and implement an algorithm called the Spanning Tree Protocol which is defined in the IEEE 802.1D standard. Spanning Tree allows switches to detect loops and internally block messages from circulating in the loop. As a result managed switches with Spanning Tree actually logically break the ring by blocking internally. This results in the equivalent of a cascading architecture with the advantage that if one of the links should break the

managed switches in the network will reconfigure themselves to span out via two paths.

Consider the following example:

- ❑ Switches 1 to N are physically connected in a ring as shown in Figure 4 and all are managed switches supporting the IEEE 802.1D Spanning Tree protocol.
- ❑ Typically, network traffic will flow in accordance with Path 1 as shown in Figure 4. Switch N will block message frames as they come full circle thereby logically preventing a message loop.
- ❑ Now, assume a physical break in the Ring occurs, let's say between Switch 3 and 4.
- ❑ The switches on the network will now reconfigure themselves via the Spanning Tree Protocol to utilize two paths: Path 1 and Path 2 as shown in Figure 4 thereby maintaining communications with all the switches. If the network had been a simple cascading architecture the physical break between switches 3 and 4 would have resulted in two isolated network segments.

While Spanning Tree Protocol (IEEE 802.1D) is useful and a must for Ring architectures or in resolving inadvertent message loops it has one disadvantage when it comes to real-time control. Time! It simply takes too long; anywhere from tens of seconds to minutes depending on the size of the network. In order to address this shortcoming the IEEE developed Rapid Spanning Tree Protocol (IEEE 802.1w) that allows for sub-second reconfiguration of the network.

Advantages:

- ❑ Rings offer redundancy in the form of immunity to physical breaks in the network.
- ❑ IEEE 802.1w Rapid Spanning Tree Protocol allows sub-second network reconfiguration.
- ❑ Cost effective cabling/wiring allowed. Similar to Cascaded architecture.

Disadvantages:

- ❑ Latency – worst case delays across the cascading backbone have to be considered if the application is very time sensitive (similar to Cascading)
- ❑ All switches should be Managed Switches. This is not necessarily a disadvantage per se but simply an added complexity. Although, the advantages of Managed Switches often far outweigh the added complexity.

## Star Architecture

A typical Star architecture is shown in Figure 4. Switch N is referred to as the

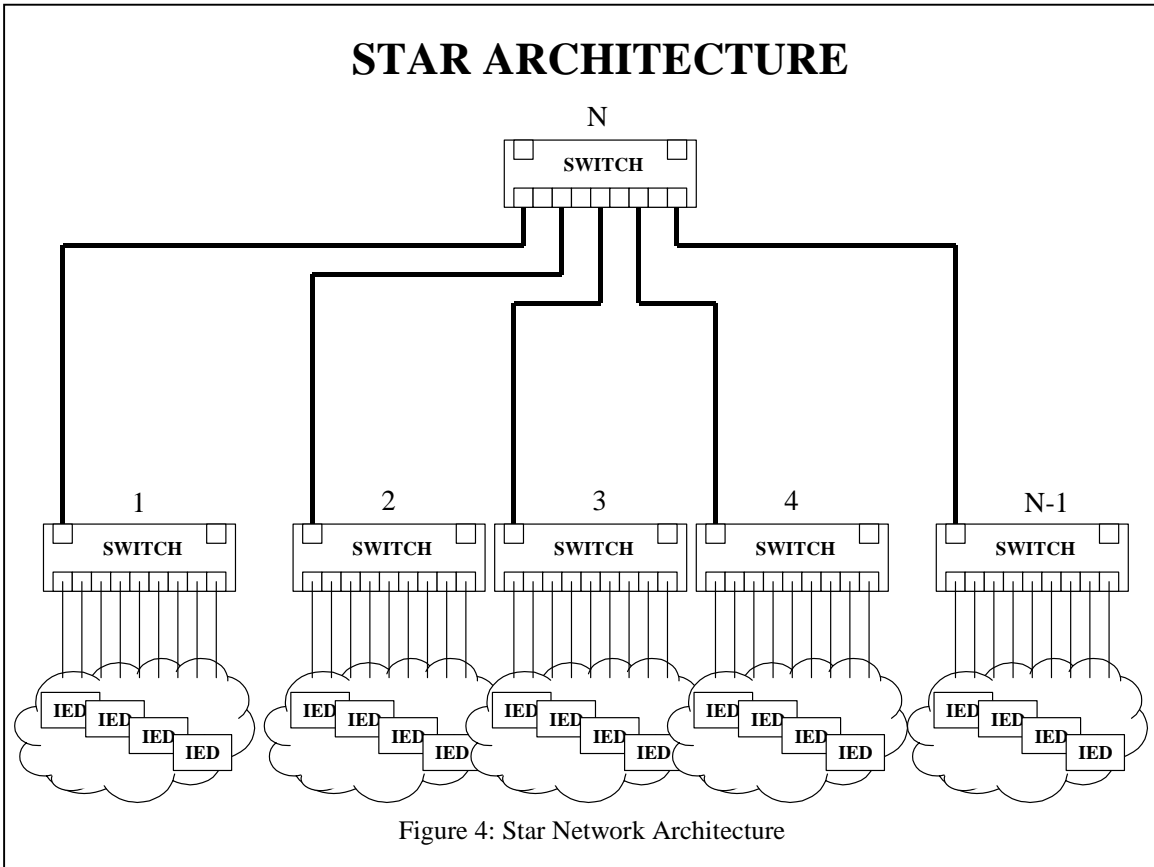

Figure 4: Star Network Architecture

'backbone' switch since all of the other switches uplink to it in order to form a star configuration. This type of configuration offers the least amount of latency (i.e. delay) since it can be seen that communication between IED's connected to any two switches, say Switch 1 and N-1, only requires the message frames to make two 'hops' (i.e. from Switch 1 to Switch N and then from Switch N to Switch N-1).

### Advantages:

- ❑ Lowest Latency - allows for lowest number of 'hops' between any two switches connected to the backbone switch N.

### Disadvantages:

- ❑ No Redundancy - if the backbone switch fails all switches are isolated or if one of the uplink connections fails then all IED's connected to that switch are lost.

## Fault Tolerant Hybrid Star-Ring Architecture

A hybrid fault tolerant architecture, combining star and ring architectures is

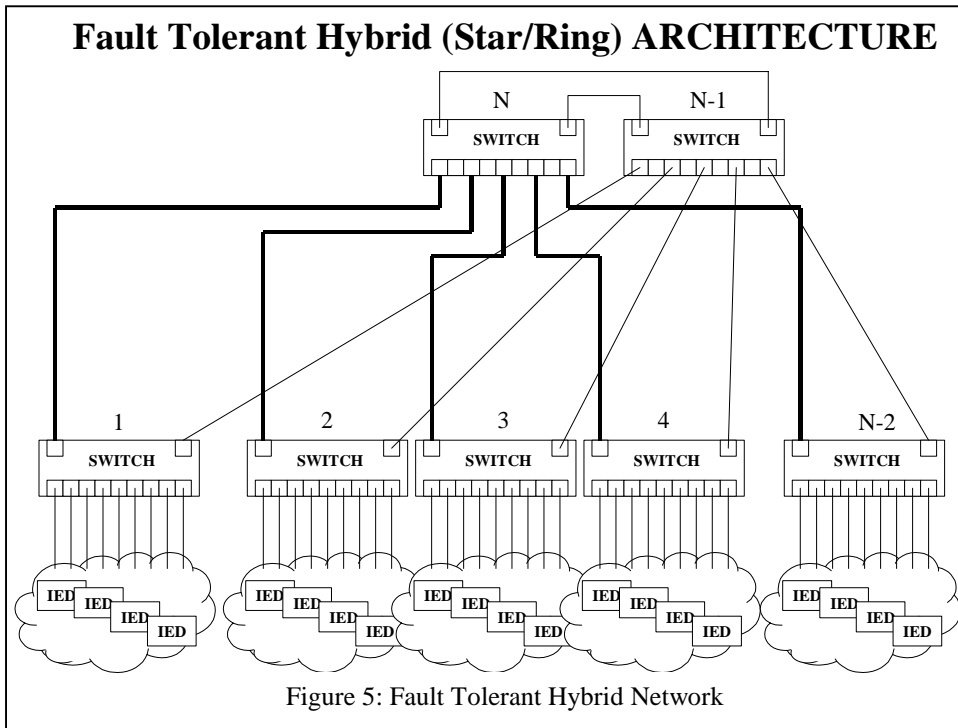

shown in Figure 5. This architecture can withstand any one of the fault types shown in Figure 6 and not lose communications between any of the IED's on the

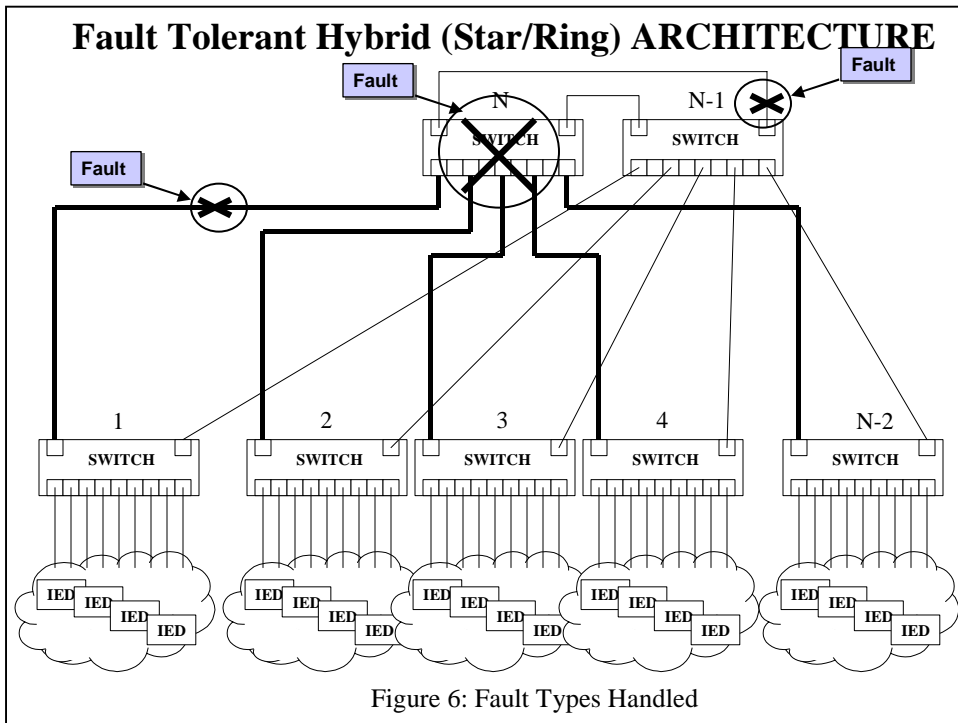

network.

### Fault Tolerant Architecture For IED's With Dual Ethernet Ports

A fault tolerant architecture is shown in Figure 7 when IED's with dual Ethernet ports are used. This architecture provides a high level of availability (i.e. uptime)

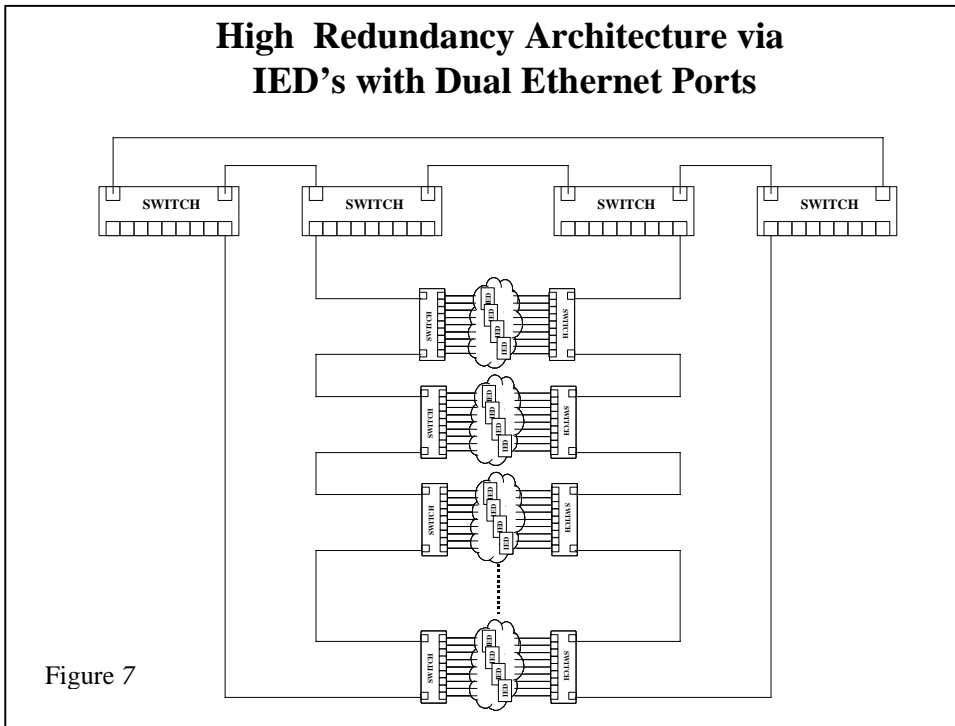

Figure 7

and is immune to numerous types of faults as shown in Figure 8.

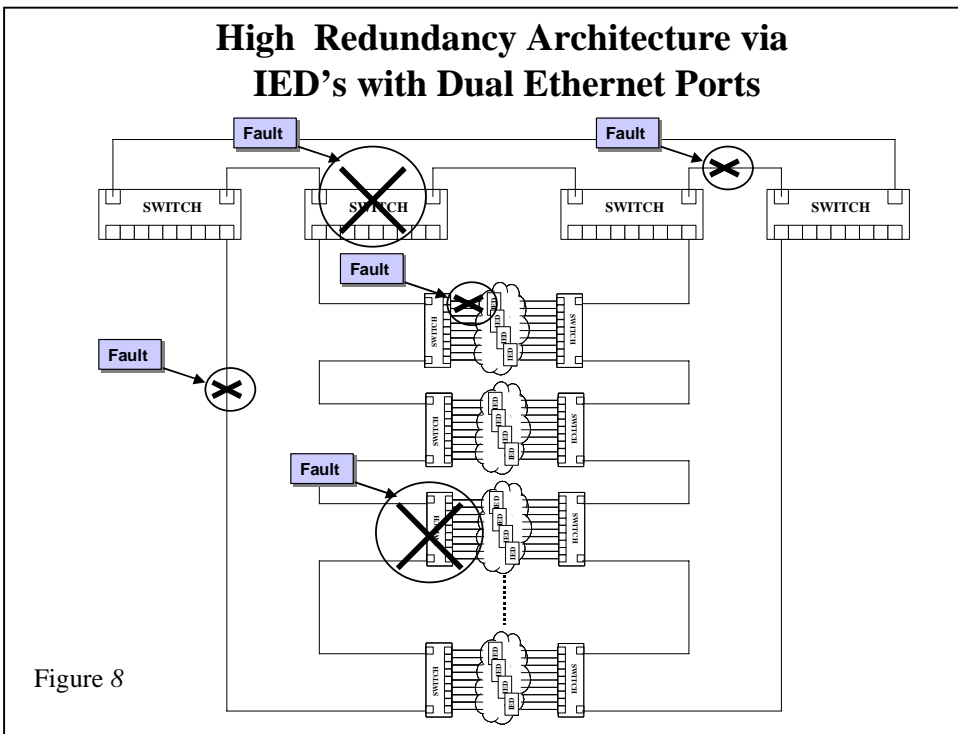

Figure 8

## Conclusions

1. Ethernet switches used in substation automation applications should comply with either
  - IEC 61850-3 or
  - IEEE P1613standards for EMI immunity and environmental requirements to ensure reliable operation of networking equipment in substation environments.
2. For applications where the Ethernet network will be involved in critical protection functions the Ethernet switches should comply with the **Class 2** device definition given in IEEE P1613 (i.e. error free communications during the application EMI immunity type tests )
3. Managed Ethernet switches with advanced Layer 2 and Layer 3 features such as:
  - IEEE 802.3 Full-Duplex operation (no collisions)
  - IEEE 802.1p Priority Queuing
  - IEEE 802.1Q VLAN
  - IEEE 802.1w Rapid Spanning Tree
  - IGMP Snooping / Multicast Filteringshould be used to ensure real-time deterministic performance.
4. A variety of flexible network architectures offering different levels of performance, cost and redundancy are achievable using managed Ethernet switches.

### **About the author:**

Marzio Pozzuoli is the founder and president of RuggedCom Inc., which designs and manufactures industrially hardened networking and communications equipment for harsh environments. Prior to founding RuggedCom Mr. Pozzuoli developed advanced numerical protective relaying systems and substation automation technology. Mr. Pozzuoli graduated from Ryerson Polytechnical Institute, Toronto, Ontario in 1986 with a Bachelor of Electrical Engineering Technology. He holds multiple patents related to advances in communications, protective relaying technology, and automation technology. He is also an active member of the IEEE and is involved standards work as a member of the IEEE Power Engineering Society Substations Committee task force C2TF1 working on developing a standard for communications networking devices in substations.

### **References:**

[1] *IEC 61850-3: “Communications networks and systems in substations – Part 3: General Requirements” (Section 5.7 EMI Immunity)*

[2] *IEC 61000-6-5 “Generic Standards – Immunity for power station and substation environments”*

[3] *IEEE P1613 “Draft Standard Environmental and Testing Requirements for Communications Networking Devices in Electric Power Substations”*

[4] *IEEE PSRC H6 PAPER - “Application Considerations of UCA 2 for Substation Ethernet Local Area Network Communication for Protection and Control”*