

AN

## Event Annunciator - AN



The Event Annunciator AN is a microprocessor based device used to indicate events (dry contacts) generated by one or more devices under control. As it is a centralizing unit, it must be applied jointly with the Data Acquisition Modules DM1 (DM specifications below) which, interconnected to the AN, make up an acquisition and variable control network. It is then possible to indicate such variables on displays or reproduce them through potential-free contacts of the Control Modules DM3. The interconnection between modules DM1 and DM3 and the annunciator is carried out through a single twisted pair cable using a RS-485 output with Modbus protocol. This interconnect configuration is ideal for applications with decentralized signals where the cabling and ducting costs make projects

unfeasible. The end result is a single twisted pair cable can replace more than 400 wires.

### General characteristics:

- Up to 400 digital inputs (the number of dry contacts is limited by the number of Input Modules DM1). N.O. or N.C. contacts are configurable through the front panel or via software.
- Up to 2 outputs for each digital input, also configurable via front panel or software in N.O. or N.C.
- Indication of up to 3 simultaneous events on an alphanumeric liquid crystal display with high resolution and backlight.
- 2 independent and insulated universal power inputs (85..265 Vdc/Vac);
- User defined alarm messages with 2 lines of 16 characters each;
- 4 ISA standard signalization sequences configurable via front panel or software in ISA1, ISA1B, ISA2A, or ISA2C;
- Reduced dimensions (144 X 144 X 125 mm);
- Internal clock with indication of hours, minutes, seconds, and dates in day/month/year and days of the week.
- Optional input for external GPS.
- Output for the signalization of internal system failure detected during the self-diagnostic procedure.
- RS-232 output to configure the Annunciator and edit event texts.
- 14 keys on the front panel for navigation;
- Output for RS-485 serial communication with Modbus RTU protocol for Supervisory or Monitoring System.



# AN

## Technical Characteristics

Power Supply: Two, 85 to 265 Vdc / Vac, 50/60 Hz  
Maximum Consumption: 5W  
Operation Temperature: -10 to 70°C

### Outputs:

- Relays  
Maximum Switching Power: 70W / 220 VA  
Maximum Switching Voltage: 250 Vdc / 250 Vac  
Maximum Conduction Current: 2.0 A
- Serial Communication: RS 485
- Power Supply Output 5V  
Rated Power: 3.5W
- Power Supply Output 12V  
Rated Power: 2.1W
- Total Weight : 0.950 kg

### Consumption of Modules DM's:

- Input Module DM110X  
Power Supply of 5V: 0.5W  
Power Supply of 12V: 1.2W
- Output Module DM310X  
Power Supply of 5V: 2W



# AN

## Connection Diagram

### INPUT MODULES (8 INPUTS\*)

\* For Modules with 16 or 24 inputs, please see the Manual of the Data Acquisition and Control Module - DM

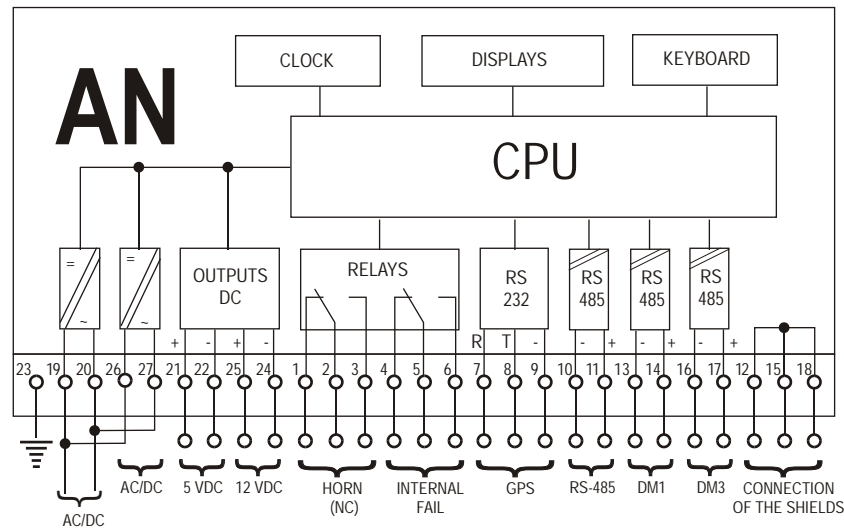
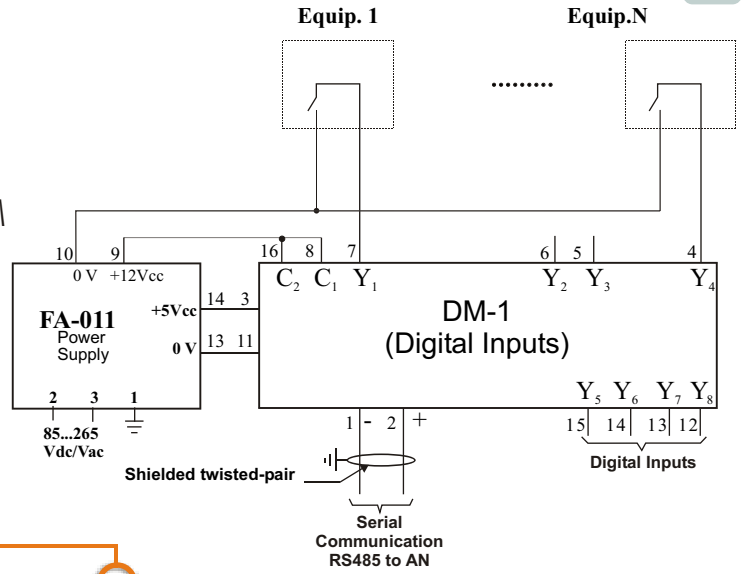

### EVENT ANNUNCIATOR MODULE -AN

### OUTPUT MODULE (8 OUTPUTS\*)

\* For Modules with 16 or 24 outputs, please see the Manual of the Data Acquisition and Control Module - DM

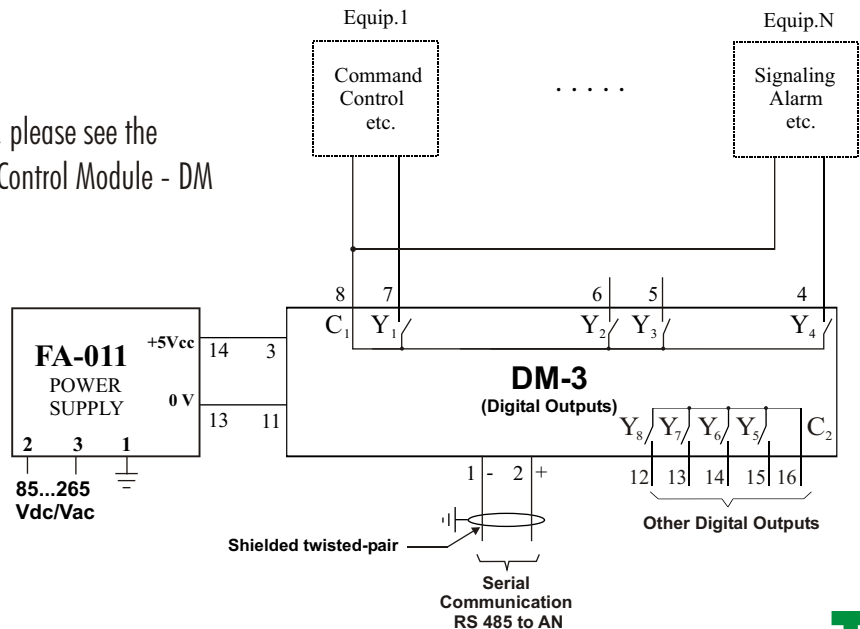

AN

Dimensions

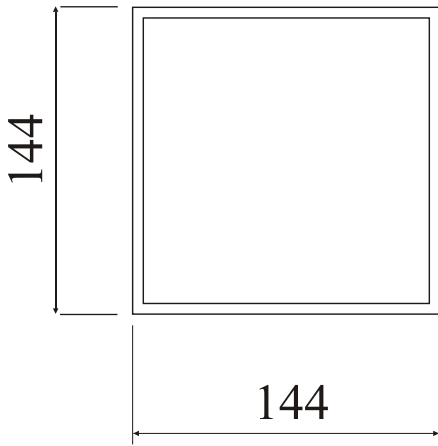

Front View

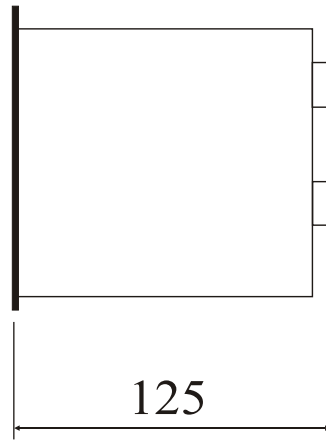

Side View

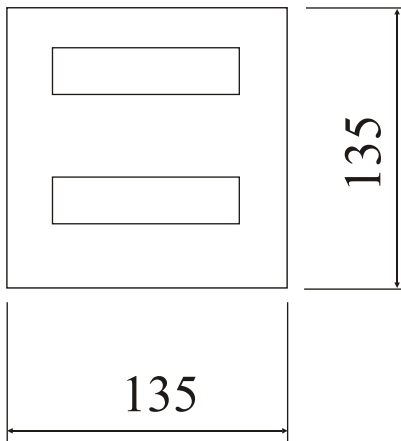

Back View

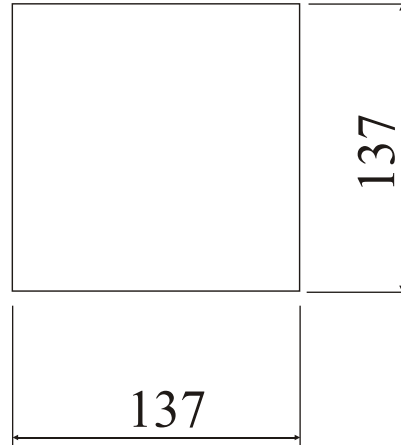

Dimensions for  
Panel cut-out

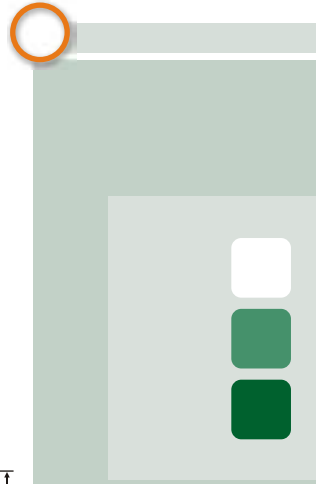

# AN

## Accomplished Tests



### Surges and transients (IEC 60255-6)

Value of peak 1 <sup>st</sup> cycle:	2.5 kV
Frequency:	1.1 MHz
Time:	2 s
Repetition rate:	400 (surtos/s)
Decline to 50%:	5 cycles

### Impulse (IEC 60255-5)

Wave form:	1.2/50 us
Amplitude:	5 kV
Number of pulses:	3 negative e 3 positive with interval of 5 seconds between pulses.
Energy:	0.5J

### Insulation Voltage (IEC 60255-5)

Insulation Voltage at industrial frequency :	2.0 kVrms, 60 Hz, during 1 minute between circuits and monting panel.
--	---

### Eletromagnetic Susceptibility(IEC 61000-4-3)

Severity Level:	3
Frequency:	26 to 2000MHz
Field Intensity:	10 V/m

### Electrostatics Discharges(IEC 61000-4-2)

Air Mode:	Level 3 (8kV)
Contact mode:	10 Discharges Level 3 (6kV)

### Fast Electrical Transients (IEC 61000-4-4)

Severity Level:	4
Test in power supply:	4kV
Test in inputs/outputs:	2kV

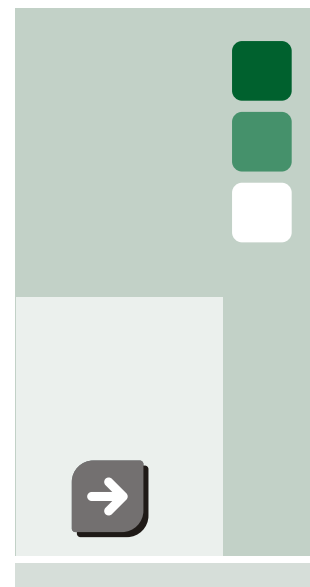

# AN

## Ordering Information



### a) Event Annunciator Module

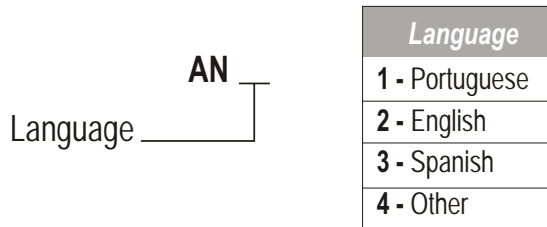

### b) Data Acquisition and Control Module - DM

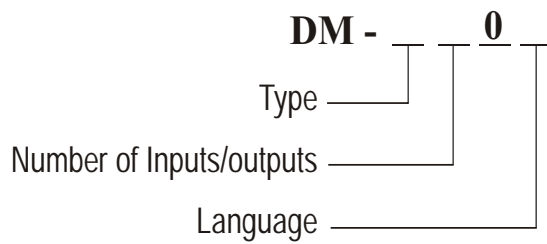

Type	Number of Inputs/outputs	Language
1 - Digital Input	1 - 8	1 - Portuguese
3 - Digital Output	2 - 16	2 - English
	3 - 24	3 - Spanish
		4 - Other

### c) Quantities:

Module AN: \_\_\_\_  
 Input Module DM1\_0: \_\_\_\_  
 Output Module DM3\_0: \_\_\_\_  
 Power Supply FA01: \_\_\_\_





Tree Tech USA  
685 Mosser Rd. Ste 124 McHenry, MD 2154  
Phone: 301-387-7012 - Fax: 301-387-7013  
e-mail: info@treetechusa.com  
www.treetechusa.com

Tree Tech Brasil  
Praça Claudino Alves, 141 • Centro -  
Atibaia - SP - CEP 12940-040  
Tel./Fax (+55 11) 4413-5787  
e-mail: comercial@treetech.com.br  
www.treetech.com.br

